

Product data sheet

Characteristics

ATSU01N209LT

soft starter for asynchronous motor - ATSU01 - 9
A - 200..480V - 1.5..4 KW

Product availability : Stock - Normally stocked in distribution facility

Price** : 152.00 USD



Main

Range of product	Altistart U01 and TeSys U
Product or component type	Soft starter
Product destination	Asynchronous motors
Product specific application	Simple machine
Device short name	ATSU01
Phase	3 phase
[Us] rated supply voltage	200...480 V - 10...10 %
Motor power kW	4 kW, 3 phase 400 V 1.5 kW, 3 phase 230 V
Maximum Horse Power Rating	2 hp, 3 phase 230 V 5 hp, 3 phase 460 V
IcL starter rating	9 A
Utilisation category	AC-53B EN/IEC 60947-4-2
Current consumption	65 mA
Type of start	Start with voltage ramp
Power dissipation in W	1.5 W at full load and at end of starting 91.5 W in transient state

Complementary

Assembly style	With heat sink
Function available	Integrated bypass
Supply voltage limits	180...528 V
Supply frequency	50...60 Hz - 5...5 %
Network frequency	47.5...63 Hz
Output voltage	<= power supply voltage
[Uc] control circuit voltage	24 V DC +/- 10 %
Starting time	1 s / 100 5 s / 20 10 s / 10 Adjustable from 1 to 10 s
Deceleration time symb	Adjustable from 1 to 10 s
Starting torque	30...80 % of starting torque of motor connected directly on the line supply

Discrete input type	Logic LI1, LI2, BOOST) stop, run and boost on start-up functions <= 8 mA 27 kOhm
Discrete input voltage	24...40 V
Input output isolation	Galvanic between power and control
Discrete input logic	Positive LI1, LI2, BOOST < 5 V <= 0.2 mA > 13 V, >= 0.5 mA
Discrete output current	2 A DC-13 3 A AC-15
Discrete output type	Open collector logic LO1 end of starting signal Relay outputs R1A, R1C NO
Discrete output voltage	24 V 6...30 V) open collector logic
Minimum switching current	10 mA 6 V DC relay outputs
Maximum switching current	Relay outputs 2 A 30 V DC cos phi = 0.5 20 ms inductive Relay outputs 2 A 250 V AC AC-15 cos phi = 0.5 20 ms inductive
Maximum switching voltage	440 V relay outputs
Display type	1 LED green)starter powered up 1 LED yellow)nominal voltage reached
Tightening torque	4.43 lbf.in (0.5 N.m) 16.82...22.13 lbf.in (1.9...2.5 N.m)
Electrical connection	4 mm screw clamp terminal - rigid 1 1...10 mm ² AWG 8 power circuit Screw connector - rigid 1 0.5...2.5 mm ² AWG 14 control circuit 4 mm screw clamp terminal - rigid 2 1...6 mm ² AWG 10 power circuit Screw connector - rigid 2 0.5...1 mm ² AWG 17 control circuit Screw connector - flexible with cable end 1 0.5...1.5 mm ² AWG 16 control circuit 4 mm screw clamp terminal - flexible without cable end 1 1.5...10 mm ² AWG 8 power circuit Screw connector - flexible without cable end 1 0.5...2.5 mm ² AWG 14 control circuit 4 mm screw clamp terminal - flexible with cable end 2 1...6 mm ² AWG 10 power circuit 4 mm screw clamp terminal - flexible without cable end 2 1.5...6 mm ² AWG 10 power circuit Screw connector - flexible without cable end 2 0.5...1.5 mm ² AWG 16 control circuit
Marking	CE
Operating position	Vertical +/- 10 degree
Height	9.21 in (234 mm)
Width	1.77 in (45 mm)
Depth	5.91 in (150 mm)
Net weight	0.75 lb(US) (0.34 kg)
Motor power range AC-3	1.1...2 kW 200...240 V 3 phase 2.2...3 kW 380...440 V 3 phase 4...6 kW
Motor starter type	Soft starter

Environment

Electromagnetic compatibility	Conducted and radiated emissions level B CISPR 11 Conducted and radiated emissions level B IEC 60947-4-2 Damped oscillating waves level 3 IEC 61000-4-12 Electrostatic discharge level 3 IEC 61000-4-2 EMC immunity EN 50082-1 EMC immunity EN 50082-2 Harmonics IEC 1000-3-2 Harmonics IEC 1000-3-4 Immunity to electrical transients level 4 IEC 61000-4-4 Immunity to radiated radio-electrical interference level 3 IEC 61000-4-3 Voltage/current impulse level 3 IEC 61000-4-5 Conducted and radiated emissions level 3 IEC 61000-4-6 Immunity to conducted interference caused by radio-electrical fields IEC 61000-4-11
Standards	EN/IEC 60947-4-2
Product certifications	UL C-Tick CSA CCC
IP degree of protection	IP20
Pollution degree	2 EN/IEC 60947-4-2
Vibration resistance	1 gn 13...150 Hz)EN/IEC 60068-2-6 1.5 mm peak to peak 3...13 Hz)EN/IEC 60068-2-6
Shock resistance	15 gn 11 ms EN/IEC 60068-2-27

Relative humidity	5...95 % without condensation or dripping water EN/IEC 60068-2-3
Ambient air temperature for operation	14...104 °F (-10...40 °C) without 104...122 °F (40...50 °C) with current derating of 2 % per °C)
Ambient air temperature for storage	-13...158 °F (-25...70 °C) EN/IEC 60947-4-2
Operating altitude	<= 3280.84 ft (1000 m) without > 3280.84 ft (1000 m) with current derating of 2.2 % per additional 100 m

Ordering and shipping details

Category	22392 - ATSU01/ATS01 LOW HP SOFT STARTERS
Discount Schedule	I11
GTIN	00785901824312
Package weight(Lbs)	0.48 kg (1.05 lb(US))
Returnability	Yes
Country of origin	DE

Offer Sustainability

RECh Regulation	REACH Declaration
RECh free of SVHC	Yes
EU RoHS Directive	Pro-active compliance (Product out of EU RoHS legal scope) EU RoHS Declaration
Toxic heavy metal free	Yes
Mercury free	Yes
RoHS exemption information	Yes
China RoHS Regulation	China RoHS declaration
Circularity Profile	End of Life Information
WEEE	The product must be disposed on European Union markets following specific waste collection and never end up in rubbish bins.

Contractual warranty

Warranty	18 months
----------	-----------

Dimensions

With TeSys U Combination (Non Reversing Power Base)

Mounting on symetrical (35 mm) rail with power connector between ATS and TeSys U.

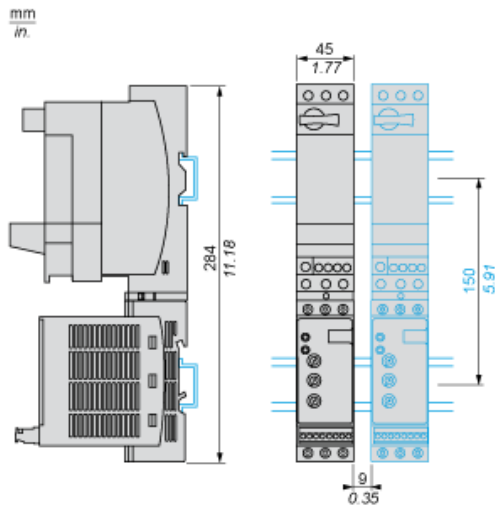

With TeSys U Combination (Non Reversing or Reversing Power Base)

Side by side mounting

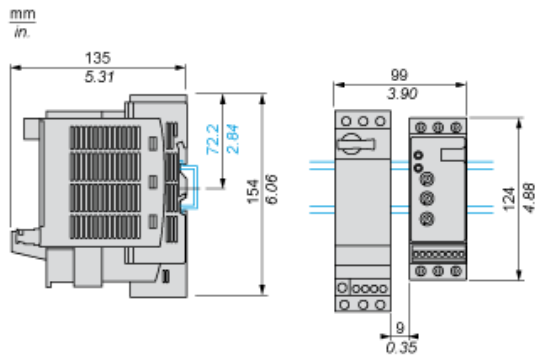

Power Wiring

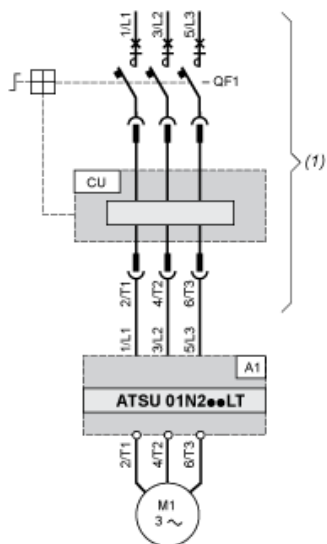

- (1) TeSys U
 A1 : Soft start/soft stop unit
 QF1 : TeSys U controller-starter
 CU : TeSys U control unit

With Reversing Unit

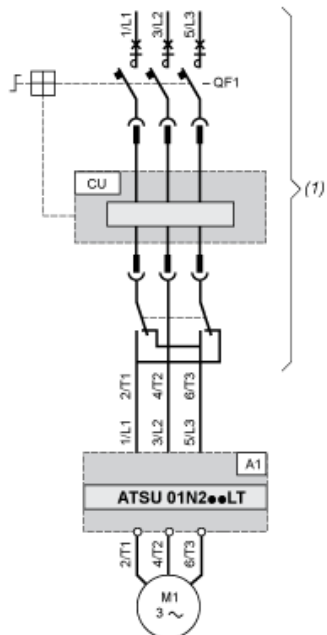

- (1) TeSys U with reversing unit
 A1 : Soft start/soft stop unit
 QF1 : TeSys U controller-starter
 CU : TeSys U control unit

Control Wiring

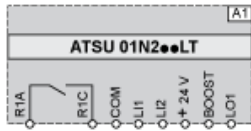

- A1 : Soft start/soft stop unit
- R1A, R1C : Relay output NO
- COM : Common
- LI1, LI2 : Logic inputs (stop and run functions)
- BOOST : Logic input (boost on start-up function)
- LO1 : Logic output

Functional Diagram Automatic 2-wire Control

Without Deceleration

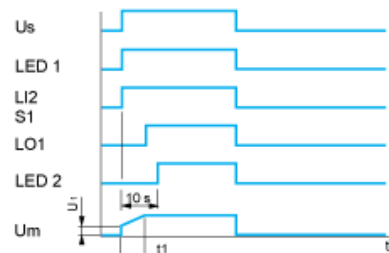

- Us : Power supply voltage
- LED 1 : Green LED
- LI2 : Logic input
- S1 : Pushbutton
- LED 2 : Yellow LED
- Um : Motor voltage
- t1 : Acceleration time can be controlled by a potentiometer
- U1 : Starting time can be controlled by a potentiometer

With and without Deceleration

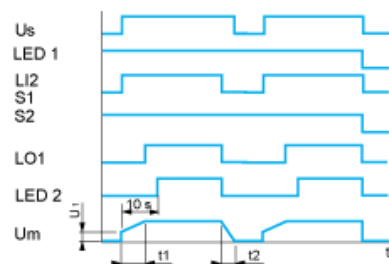

- Us : Power supply voltage
- LED 1 : Green LED
- LI2 : Logic input
- S1, S2 : Pushbuttons
- LO1 : Logic output
- LED 2 : Yellow LED
- Um : Motor voltage
- t1 : Acceleration time can be controlled by a potentiometer
- t2 : Deceleration time can be controlled by a potentiometer
- U1 : Starting time can be controlled by a potentiometer

Functional Diagram Automatic 3-wire Control

Without Deceleration

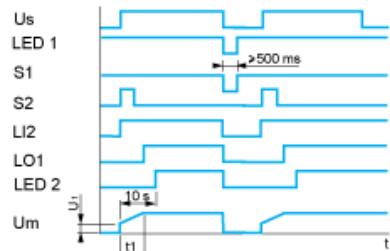

- Us : Power supply voltage
- LED 1 : Green LED
- S1, S2 : Pushbuttons
- LI2 : Logic input
- LO1 : Logic output
- LED 2 : Yellow LED
- Um : Motor voltage
- t1 : Acceleration time can be controlled by a potentiometer
- U1 : Starting time can be controlled by a potentiometer

With Deceleration



- Us : Power supply voltage
- LED 1 : Green LED
- S1, S2 : Pushbuttons
- LI1, LI2 : Logic inputs
- LO1 : Logic output
- LED 2 : Yellow LED
- Um : Motor voltage
- t1 : Acceleration time can be controlled by a potentiometer